

# ECLIPSE RATIOMATIC BURNERS

Data 110-6

## Model 400 RM—Version 1.01

6/95

For Serial Numbers 95-5500 & Above

### Specifications

Input vs. Chamber Pressure	4,670,000 Btu/hr. @ -5.0" w.c.	1369 kW @ -12.5 mbar
	4,590,000 Btu/hr. @ -3.0" w.c.	1345 kW @ -7.5 mbar
	4,200,000 Btu/hr. @ -1.0" w.c.	1231 kW @ -2.5 mbar
	<b>4,000,000 Btu/hr. @ 0.0" w.c.</b>	<b>1172 kW @ 0.0 mbar</b>
	3,800,000 Btu/hr. @ +1.0" w.c.	1112 kW @ +2.5 mbar
	3,580,000 Btu/hr. @ +2.0" w.c.	1049 kW @ +5.0 mbar

**Input may be increased by 20% if sufficient secondary air is available to complete combustion.**

**Minimum Input** 65,000 Btu/hr. (19.1 kW) with neutral chamber. Will be slightly higher with negative chamber pressure.

**Turndown** 73:1 with neutral chamber pressure.

Configurations	Burner Configuration	Max. Chamber Temp.	Assy. No.
	Cast head & alloy tube	1500° F (816° C)	110198
	Alloy head & refractory block	1800° F (982° C)	110232-1

Maximums shown are for average installations. Depending on conditions, higher temperatures can be obtained. Contact Eclipse for details.

**Fuel** Standard nozzle burns natural gas, propane, propane/air mixes without changing internals. Contact Eclipse for other fuels.

**Gas Inlet Pressure**  
at proportionator inlet  
Minimum: 17" w.c. (42 mbar) natural gas, .65 s.g.  
Maximum: 2 psig (138 mbar) natural gas, .65 s.g.

**Pilot Gas Pressure**  
at pilot cock inlet  
Minimum: 6" w.c. (15 mbar) natural gas, .65 s.g.

**High Fire Flame Length** 54" (1.37 m)  
Measured from the end of the firing tube, firing parallel to air flow with neutral chamber pressure. When firing perpendicular to air flow, flame length will be shorter. Contact your local Eclipse representative for details.

**Piloting** Integral spark-ignited pilot; ignition plug included.

**Flame Monitoring** Flame rod included; UV scanners & mounting kits available.

**Control Motor Requirements** 90° travel with full stroke timing of 15 seconds or longer. Ovens with high chamber drafts or backpressures may require less than a full 90° stroke. In these cases, use adjustable stroke motors or motors equipped with travel-limiting auxiliary switches. See Bulletin 720.

**Emissions** Ratiomatics produce low NO<sub>x</sub>, CO and aldehydes. Emissions performance depends not only on the burner, but also factors such as chamber temperature, chamber design, and heat loading. For estimates of Ratiomatic performance in your application, call Eclipse.

**Packaging Options** IRI or NFPA type valve trains, and UL recognized valve packages available.

**CAUTION:** It is dangerous to use any fuel burning equipment unless it is equipped with suitable flame sensing devices and automatic fuel shut-off valves. Eclipse can supply such equipment or information on alternate sources.



## Dimensions, 400 RM

Dimensions are subject to change without notice. Contact Eclipse for certified prints prior to fabrication or installation.  
Blower motor and air filter positions can be reversed in the field.

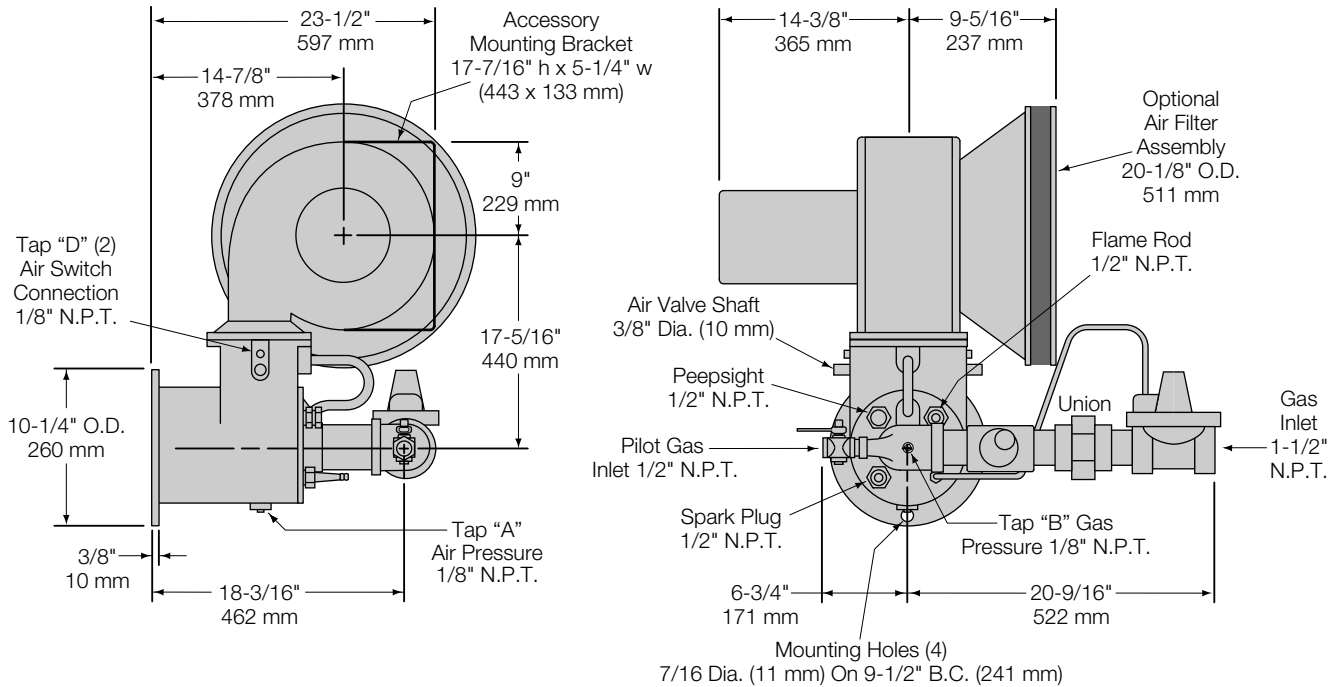

### Alloy Tube Assembly

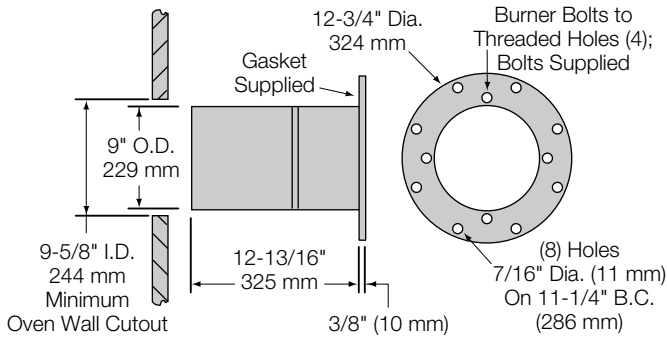

### Block & Holder Assembly

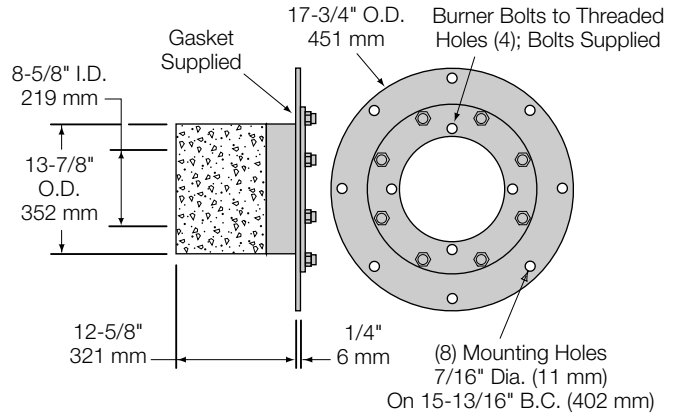

## Component Information

Item	Description	Part #
400 RM Burner Assembly	With Standard Head and Alloy Tube Assembly	110198
	With Alloy Head and Block & Holder Assembly	110232-1
Air Filter Assembly	Optional	110282
Replacement Filter Element	—	11128
Spark Plug & Flame Rod <sup>1</sup>	For burner with tube or block.	13581
Alloy Tube Assembly <sup>2</sup>	With two gaskets	110247
Block & Holder Assembly <sup>2</sup>	—	187150-61
Blower Motor <sup>1</sup>	2 hp, 230/460/3/60 TEFC, 3600 RPM	17032
Proportionator <sup>1</sup>	Eclipse ES 367, 1-1/2"	10314
Pilot Cock <sup>1</sup>	Eclipse lever handle, 1/2"	10627
Gas Adjusting Butterfly <sup>1</sup>	Eclipse 106 BV, 1-1/2"	500990

<sup>1</sup> Included with burner assembly.

<sup>2</sup> Not interchangeable in the field. Call Eclipse to convert from tube to block or vice versa.



**Offered By:**

Power Equipment Company  
2011 Williamsburg Road  
Richmond, Virginia 23231  
Phone (804) 236-3800  
Fax (804) 236-3882

---

[www.peconet.com](http://www.peconet.com)